



COMPLIANCE:

- ICAO Annex. 14, Vol.I
- FAA AC 150/5345-46
- IEC-TS 61827
- EASA: CS-ADR-DSN.
- STANAG 3316
- AENA PPT-010_03-12



BOARDING TIME



BOARDING PASS

NAME OF PASSANGER	
FROM:	
TO:	
DATE	FLIGHT GAES2020
GATE 23	SEAT 21B

GOMINTEC
BOARDING PASS
GOMINTEC

GATE CLOSSES 30 MINUTES BEFORE DEPARTURE

Uses

LED In-pavement approach side row light for airports CAT I, II y III, according to ICAO, Figure A2-2.

Features

- 12" external diameter, with upper and lower cover manufactured on high strength forged aluminum, and only 6mm of profile over pavement.
- Stainless steel hardware.
- Uni-directional and bi-directional configuration.
- Surface treatment to prevent the wear and increase the corrosion resistance, which makes it especially resistant to dust and water.
- Smooth surface without sharpened edges to avoid damages at the aircraft tyres.
- Regulation according to FAA EB67E equivalent to a halogen lamp.
- Integrated surge protection.
- Efficient control of LEDs operating temperature, increasing the light life and avoid color change.
- High features optical design.
- Compatible with existing circuits of visual aids.

Specifications

- Power: 2.8A ~ 6.6A, according to FAA EB67D.
- Average life: minimum 60.000h at maximum brightness and 100.000h in a normal operating conditions.
- Color: Red
- Consumption 36VA; FP >0,95
- Index Protection: IP68.

APSS-12-LED | LED In-pavement approach side row light - Airsafe

Order Code

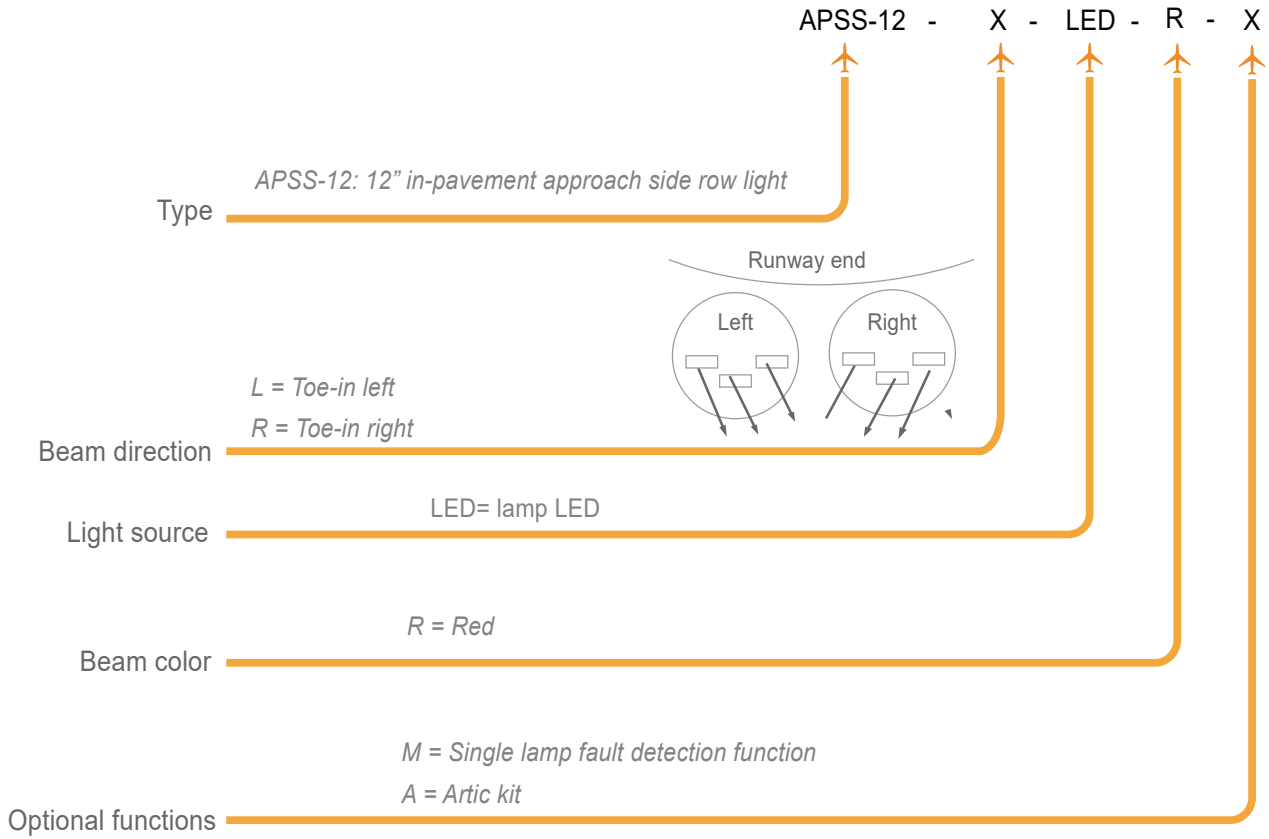

Installation

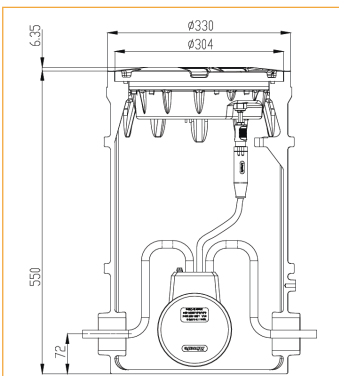

Figure 1
On 12" deep base

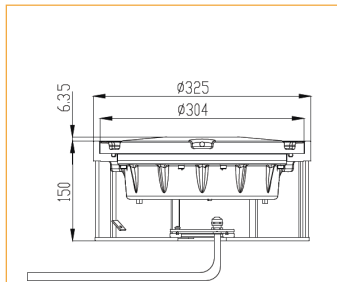
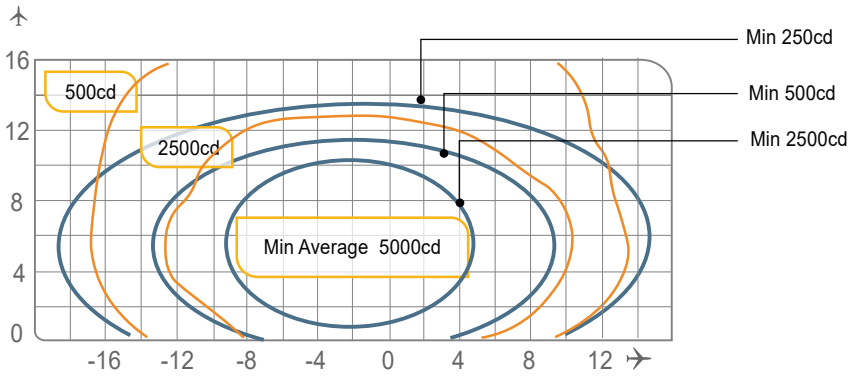

Figure 2
On 12" shallow base

APSS-12-LED | LED In-pavement approach side row light - Airsafe

Photometry



APSS-12-LED, ICAO Fig. A2-2, Red

Application		Main beam		Color	Required min. avg. cd.	Actual avg. cd.
		H	V			
APSS-12-LED	ICAO Fig A2-2 (Toe-in 2°)	± 7°	0,5° a 10,5°	Red	5.000	5.089
		± 7°	1° a 11°	Red	5.000	5.965
		± 7°	1,5° a 11,5°	Red	5.000	5.889



Structure

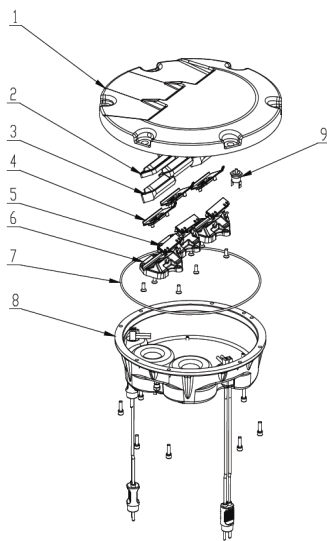

- 1 Upper cover
- 2 Prism gasket sleeve
- 3 Prism
- 4 LED lamp assy
- 5 Prism gasket
- 6 Prism pressing bracket
- 7 Light body gasket
- 8 Inner cover assy
- 9 Thermal switch

Spare Parts

N°	Order No.	Description
2	43117	Prism gasket sleeve
3	31158	Prism
4	932053-APSS-R-M	LED lamp assy
5	43316	Prism gasket
6	43241	Prism pressing bracket
7	41135	Light body gasket

Accessories

N°	Order No.	Description
1	SB-12	12" deep base
2	DB-12	12" shallow base
3	41115	12" base O-ring
4	51121	12" lamp handle
5	ITF-065-066	65W isolation transformer
6	REC7	Moulded type secondary cable receptacle style 7



Weight and Dimensions

	Base	12" shallow base
Packaging size	330x330x150mm ³	350x350x185mm ³
Weight	9,7 kg	14,260 kg