

TAES-12-LED | LED in-pavement runway threshold/end light - Airsafe

Order Code

TAES-12 - X - LED - GR - XX - X

Type *TAES-12 = 12" in-pavement runway threshold/end light*

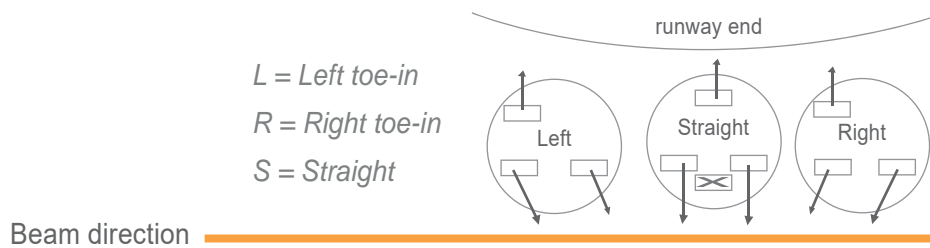

Beam direction *LED = LED lamp*

Light source *GR = Window 1: green / Window 2: red*

Beam color

Plug *1P = 1 plug*
2P = 2 plugs

Optional functions *M = Single lamp fault detection function*
A = Artic Kit
D = FAA L-850D

Installation

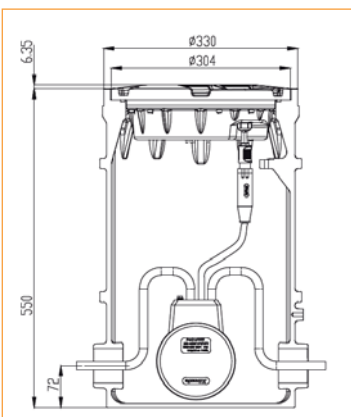

Figure 1
On 12" deep base

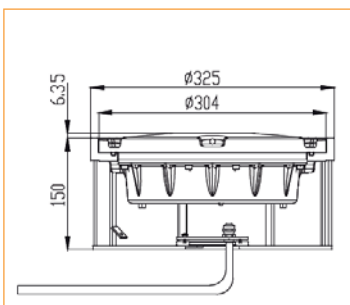
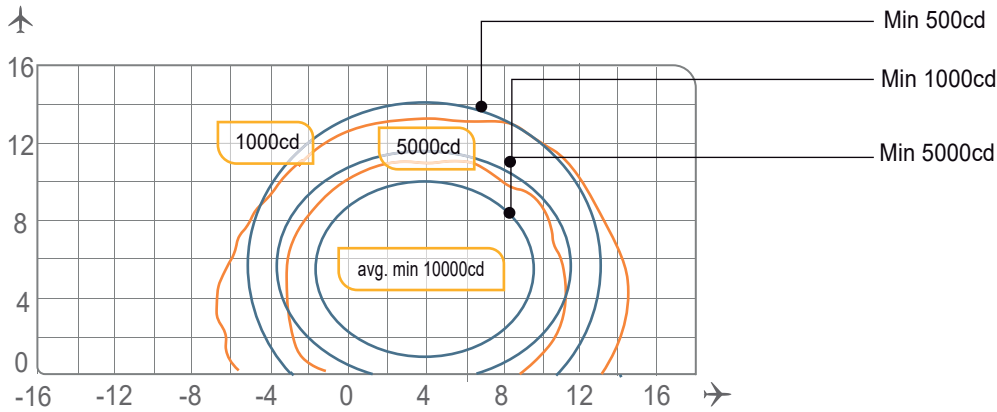
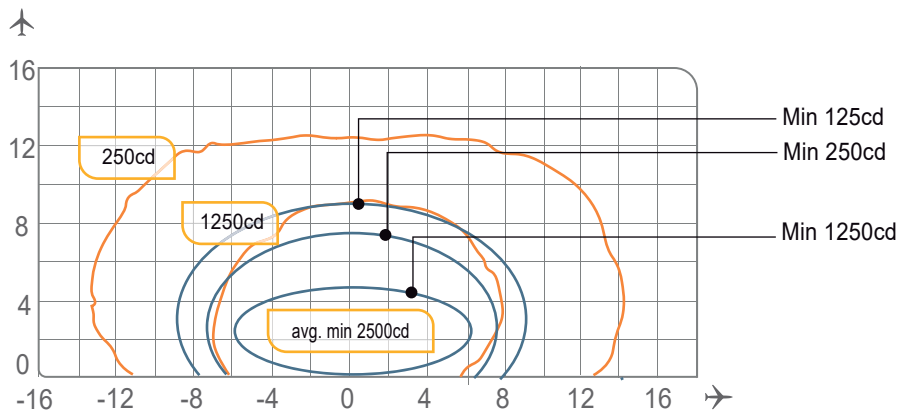

Figure 2
On 12" shallow base

Photometry



TAES-12-LED, ICAO Fig. A2-3, Green



TAES-12-LED, ICAO Fig. A2-8, Red, FAA L-850D

Application		Main beam		Color	Required min. avg. cd.	Actual avg. cd.
		H	V			
TAES-12-LED	ICAO Fig A2-3	±5,5° (toe-in 3,5°)	1° a 10°	Green	10.000	12.836
	ICAO Fig A2-8	±6°	0,25° a 4,75°	Red	2.500	3.034
TAES-12-LED-D	FAA L-850D	±5,5° (toe-in 3,5°)	1° a 10°	Green	3.300	4.164
		±6°	0,2° a 4,7°	Red	2.500	2.973

Structure

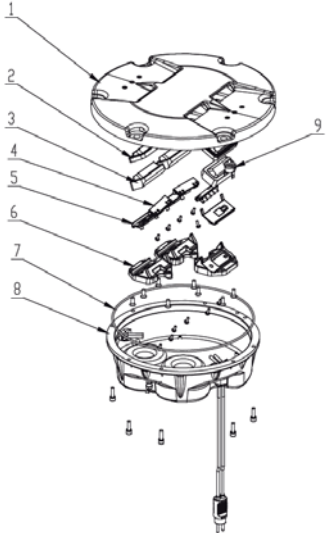

- 1 Upper cover
- 2 Prism gasket sleeve
- 3 Prism
- 4 LED lamp assy
- 5 Prism gasket
- 6 Prism pressing bracket
- 7 Light body gasket
- 8 Inner cover assy
- 9 Thermal switch

Spare Parts

N°	Order No.	Description
2	43117	Prism gasket sleeve
3	31158	Prism
4	932053-THRS-G	LED lamp assy THRS-G
	932053-ENDS-R	LED lamp assy ENDS-R
5	43316	Prism gasket
6	43241	Prism pressing bracket
7	41135	Light body gasket

Accessories

N°	Order No.	Description
1	SB-12	12" shallow base
2	DB-12	12" deep base
3	41115	12" base O-ring
4	51121	12" lamp handle
5	ITF-065-066	65W isolation transformer
6	REC7	Secondary cable connector style 7



Weight and Dimensions

	Base	12" shallow base
Packaging size	330x330x150mm ³	350x350x185mm ³
Weigh	7,04 kg	15,6 kg