

RAP-08 | In-pavement rapid exit taxiway indicator - Airsafe



COMPLIANCE:

- ICAO Annex.14 Vol.1
- FAA AC 150/5345-46
- IEC-TS 61827
- EASA: CS-ADR-DSN
- STANAG 3316
- AENA PPT-013_03-12

BOARDING TIME

BOARDING PASS

NAME OF PASSANGER

FROM:

TO:

DATE FLIGHT

 GAES2020

GATE SEAT

23 21B

GATE CLOSES 30 MINUTES BEFORE DEPARTURE

GOMINTEC BOARDING PASS GOMINTEC

Uses

In-pavement rapid exit taxiway indicator light for airports CAT I, II & III, according to ICAO, Figures A2-6 & A2-7.

Features

- 8" external diameter.
- Body casting manufactured on forged aluminum, with high strength and optimum mechanical performance.
- A patented prism design to guarantee an excellent optical performance and ensures high resistance to temperature and pressure changes.
- The upper cover is designed with a flat surface at the light beam exits to prevent the accumulation of water and ensure high luminous efficiency.
- Bulb fixing design based on suspension mounting to effectively extend bulb's lifetime
- Use of standard halogen reflector lamps.
- No adjustments required after lamp or another optical component replacement.
- High precision machining of parts and components to guarantee the quality and dimensions of each piece.
- Stainless steel hardware to grant the waterproof and corrosion resistance.
- Multi-slip waterproof gasket to ensure an appropriate seal with the base.
- Interchangeable components, usable in all lights of the range.

Specifications

- Power: 2.8A ~ 6.6 A.
- Lamp: 1x48W/6.6A halogen lamp with reflector.
- Lamp average life: More than 1.500h at maximum brightness and more than 3.000h in a normal operation conditions.
- Color: Yellow
- Index Protection: IP68.

RAP-08 | In-pavement rapid exit taxiway indicator - Airsafe

Order Code

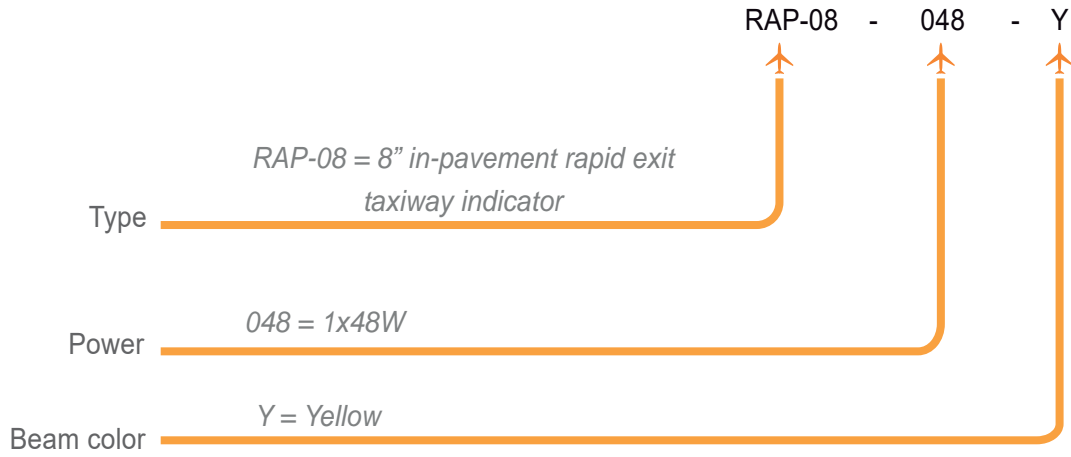

Installation

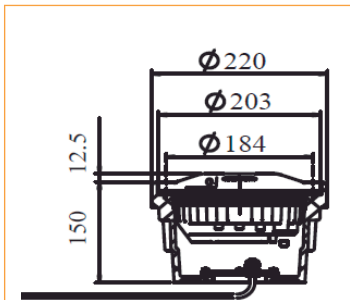

Figure 1
On 8" shallow base

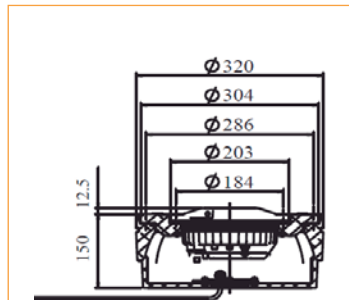

Figure 2
On 12" shallow base with 12"/8" adapter ring

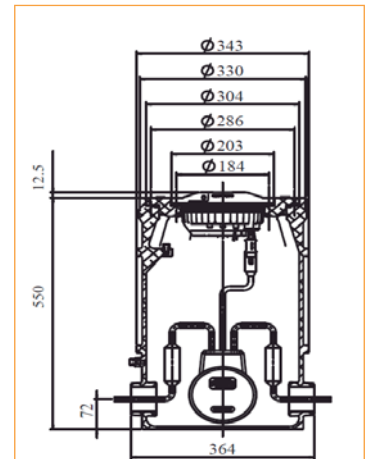
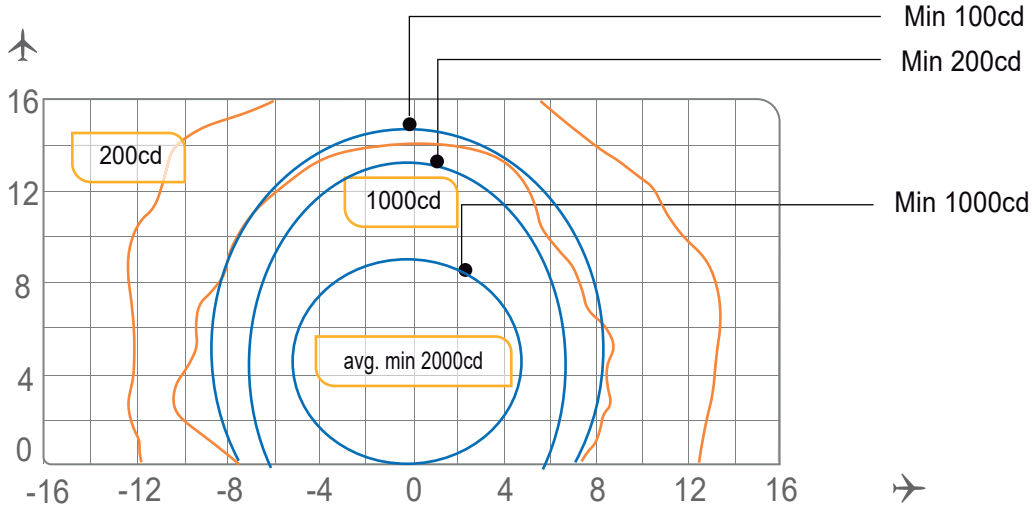

Figure 3
On 12" deep base with 12"/8" adapter ring

RAP-08 | In-pavement rapid exit taxiway indicator - Airsafe

Photometry



END-12, ICAO Fig. A2-8, Red

Application		Main beam		Color	Required min. avg. cd.	Actual avg. cd.
		H	V			
RAP-08	ICAO Fig A2-7	±5°	0° a 9°	Yellow	2.000	3.23
	ICAO Fig A2-6	±5°	0° a 7°	Yellow	2.000	3.557



Structure

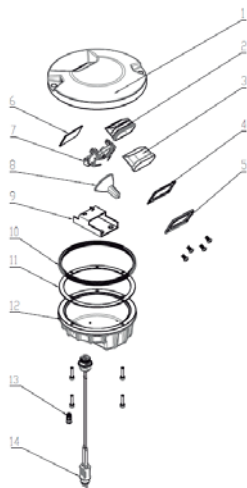

- 1 Upper cover
- 2 Prism gasket sleeve
- 3 Prism
- 4 Prism gasket
- 5 Prism pressing bracket
- 6 Filter
- 7 Lamp holder
- 8 Lamp
- 9 Mounting plate assy
- 10 Light body gasket
- 11 Lighting fixture gasket
- 12 Inner cover
- 13 Valve
- 14 Plug

Spare Parts

N°	Order No.	Description
2	43107	Prism gasket sleeve
3	31141	Prism
4	43307	Prism gasket
5	43208	Prism pressing bracket
6	31316-Y	Filter - yellow
7	942133	Lamp holder
8	L64337	Halogen lamp 48W/6.6A
10	41107	Light fixture gasket
11	41141	Light body gasket
13	941801	Valve
14	70620	Plug

Accessories

N°	Order No.	Description
1	SB-08	8" shallow base
2	SB-12	12" shallow base
3	DB-12	12" deep base
4	AR-12/08	12"-8" adapter ring assy
5	951101	8" lamp holder
6	ITF-065-066	65W isolation transformer
7	REC7	Secondary cable connector style 7



Weight and Dimensions

	Base	8" shallow base
Packaging size	210x210x130mm ³	240x240x180mm ³
Weight	3,1 kg	6,0 kg