



COMPLIANCE:

- ICAO Aerodrome Design Manual Part. 5
- FAA AC 150/5345-10
- IEC: 61822
- AENA: PPT_002-05_13

BOARDING TIME

BOARDING PASS

NAME OF PASSANGER

FROM:

TO:

DATE FLIGHT
 GAES2020

GATE SEAT
23 21B

GATE CLOSSES 30 MINUTES BEFORE DEPARTURE

GOMINTEC
BOARDING PASS
GOMINTEC

Uses

The CCR-2100 constant current regulator is especially designed for the supply of airport lighting series circuits at various intensity levels.

Features

The CCR-2100 is a modern microprocessor controlled thyristor regulator. Its new set-up allows on-site upgrading, from a basic constant current regulator to a full option unit including the following features:

- Full digitally controlled and regulated CCR.
- High constant current precision and high reliability.
- DSP and ARM microprocessor embedded processing control.
- Fully digitalized high precision control and regulation, via parameters processed in a numerical way to overcome affection by temperature, voltage or other physical parameters.
- Suitable to circuit configurations consisting of non linear loads like new technology LED lights and taxiway signs with light sources other than halogen lamps.
- Remote network control, monitoring and diagnostic functionality.
- Integrated menu driven human machine interface (HMI) allowing full configuration on-site without any additional equipment.
- Standard built-in lamp fault detection.
- Optional earth fault detector, lightning arrestors and field circuit isolator.
- Optional 2, 3 or 4 ways output circuit built-in selector.

Concept

The innovative design principle adopted for CCR-2100 family is based on transferring most of the power control tasks from the hardware circuits into the software processing of control algorithms.

- The CCR's operating principle is based on back to back coupled thyristors adjusting the supply to the transformer. A digital regulator determines the thyristor firing angle to adjust the output current to a reference value. The reference value varies with the selected brightness step.
- An A/D converter at the secondary side of the output transformer measures the output signal. The high speed DSP allows for real time control and decreases the regulation dynamics to 10ms.
- The same microprocessor also detects the lamp and earth faults and manages any other useful status information for local or remote control and monitoring.
- The remote control and monitoring can either be realized via multi-wire, or serial bus via single or dual CAN-bus connection.
- Common filter protects the main for harmonic pollution on the mains.

CCR-2100 Block Diagram

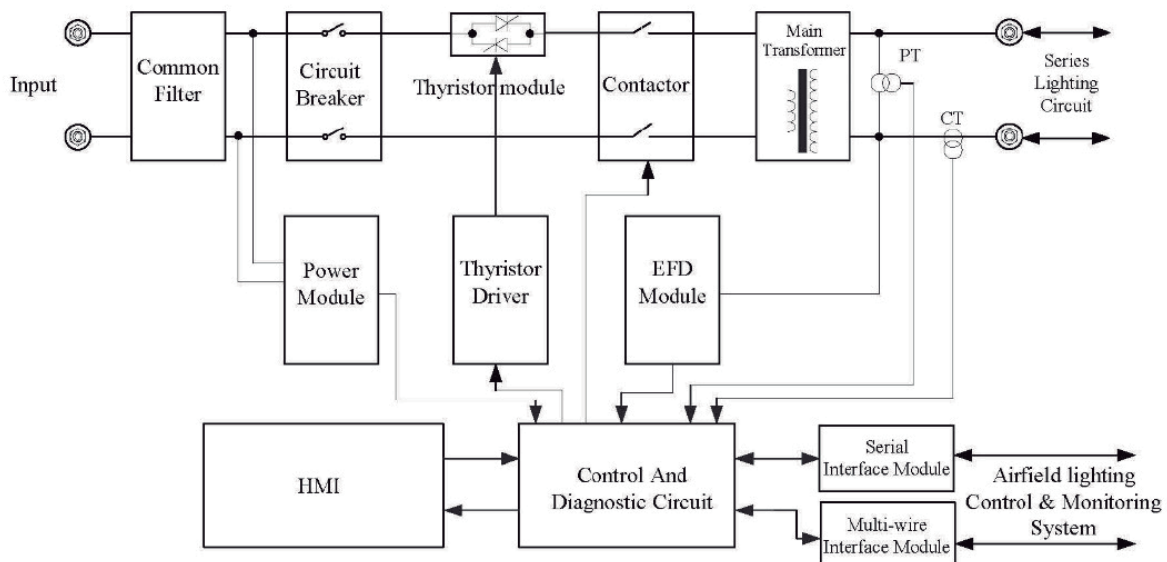

Order Code

Type of CCR

CCR-2100

5 -

B -

D

Output Power

02 = 2.5 kVA	15 = 15 kVA
05 = 5 kVA	20 = 20 kVA
07 = 7.5 kVA	25 = 25 kVA
10 = 10 kVA	30 = 30 kVA

Input Voltage
(50/60 Hz)

A = 220/240V
B = 380/400V

Remote Control

M = Multiwire C = Single J-BUS
A = Single CAN-BUS D = Dual J-BUS
B = Dual CAN-BUS

Dimensions

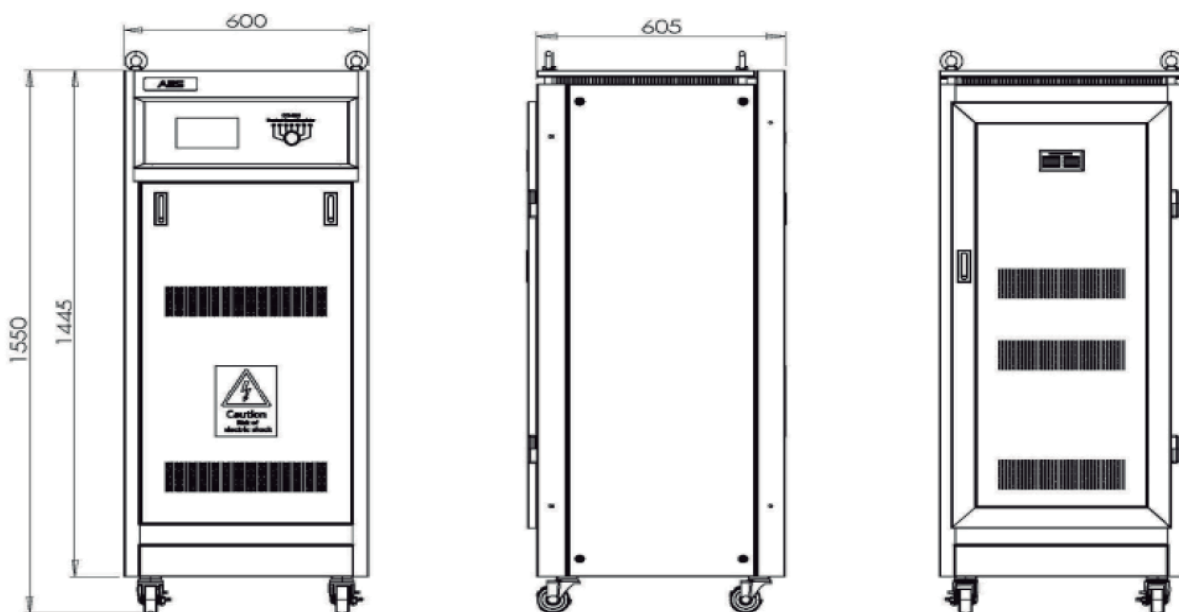

Specifications

Performance figures are always equal to or better than specified hereunder.

ENVIRONMENTAL CONDITIONS

Under IEC 61822 environmental conditions

Ambient Temperature: -25°C ~ +55°C

Altitude: 0~5000m

COOLING

Natural air cooling for all ratings

ENCLOSURE

The CCR-2100 type CCRs are stand-alone units housing the complete regulator in one enclosure.

Baked epoxy powder coating color RAL 7035

Dimensions (W×D×H) mm : 600×600×1445 (All power ratings)

RATINGS

2.5, 5, 7.5, 10, 15, 20, 25, 30kVA.

INPUT VOLTAGE RATINGS

220/240 VAC or 380/400VAC ± 10% 50/60Hz Single phase

REMOTE CONTROL

Multi-wire: 24 or 48 V DC

Multiplex: Protocolo CAN-Bus protocol, Single or Dual J-BUS protocol over RS485

BRIGHTNESS CONTROL

Up to 6 brightness steps.

Within ±1% for all the brightness steps, under either IEC or FAA standard conditions.

REGULATIONS RESPONSE TIME

The regulation time is less than 0.5 seconds for any operational condition.

EFFICIENCY

The average efficiency of each nominal current step is not less than 80%, under nominal resistive load, nominal output current and nominal input voltage.

POWER FACTOR AT THE OUTPUT

IEC types: > 0,9 for all ratings

FAA types: > 0,95 for all ratings

Adjusting the taps on the secondary of the output transformer allows to match the CCR to the actual load of the series circuit to improve the power factor, reducing also the output waveform crest factor.

NOISE

Less than 50 dB



Structure

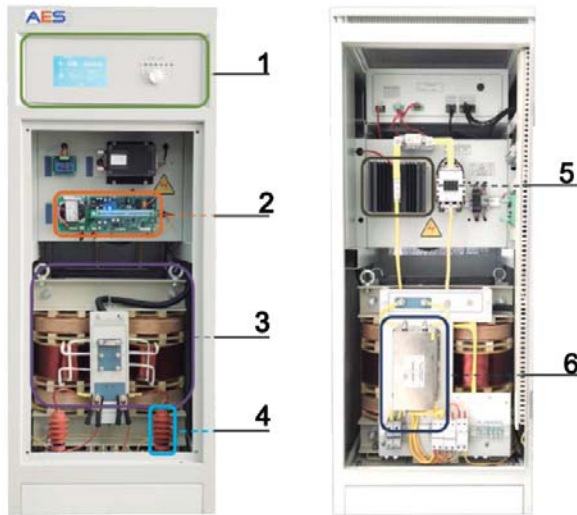

- 1 Control board
- 2 Earth fault detection
- 3 Main transformer
- 4 Lightning rod
- 5 Thyristors
- 6 Filter EMC