

TDZS-12 | LED In-pavement runway touchdown zone light - Airsafe



COMPLIANCE:

- ICAO Annex.14 Vol.1
- FAA AC 150/5345-46
- IEC-TS 61827
- EASA: CS-ADR-DSN
- STANAG 3316
- AENA PPT-012_03-12



BOARDING TIME

BOARDING PASS

NAME OF PASSANGER	
FROM:	TO:
DATE	FLIGHT GAES2020
GATE 23	SEAT 21B

GOMINTEC
BOARDING PASS
 GOMINTEC

Uses

LED In-pavement runway touchdown zone light for airports CAT I, II & III, according to CAO, Figure A2-5.

Features

- 12" external diameter, with upper and lower cover manufactured on high strength forged aluminum, and only 6mm of profile over pavement.
- Stainless steel hardware.
- Surface treatment to prevent the wear and increase the corrosion resistance, which makes it especially resistant to dust and water.
- Smooth surface without sharp edges to avoid damages at the aircraft tyres.
- Regulation according to FAA EB67E equivalent to a halogen lamp.
- Integrated surge protection.
- Efficient control of LEDs operating temperature, increasing the light life and avoid color change.
- High features optical design.
- Compatible with existing circuits of visual aids.

Specifications

- Power: 2.8A ~ 6.6A, according to FAA EB67D.
- Average life: minimum 60.000h at maximum brightness and 100.000h in a normal operating conditions.
- Color: White
- Consumption 20VA ; FP >0,95
- Index Protection: IP68.

TDZS-12 | LED In-pavement runway touchdown zone light - Airsafe

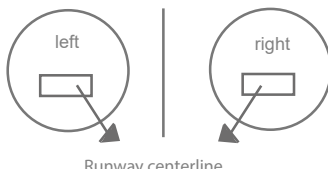
		Order Code
Type	TDZS-12 = 12" runway touchdown zone light	TDZS-12
Beam direction	L = Toe-in left R = Toe-in right 	X
Light source	LED	LED
Beam color	C = Clear (White)	C
Optional functions	M = Single lamp fault detection function A = Artic kit	X

Installation

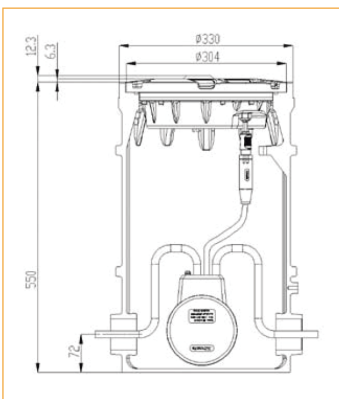

Figure 1
On 12" deep base

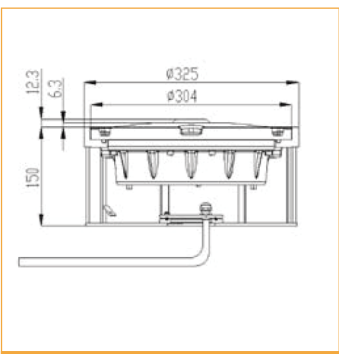
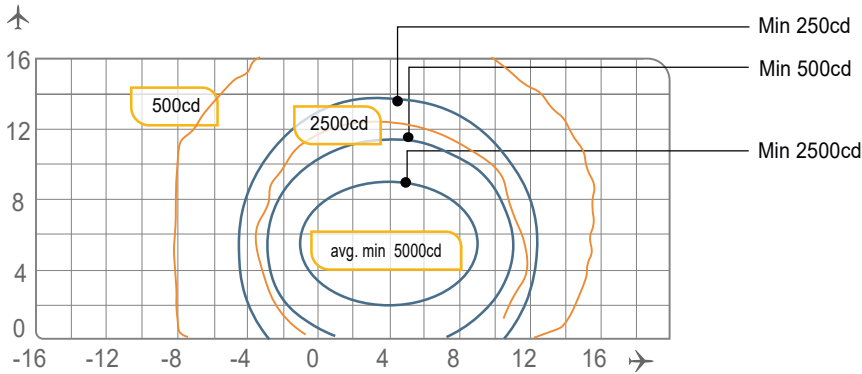

Figure 2
On 12" shallow base

TDZS-12 | LED In-pavement runway touchdown zone light - Airsafe

Photometry



TDZS-12-LED, ICAO Fig. A2-5, White

Application		Main beam		Color	Required min. avg. cd.	Actual avg. cd.
		H	V			
TDZS-12-LED	ICAO Fig A2-5	±5° (Toe-in 4°)	2° a 9°	White	5.000	6.683



Structure

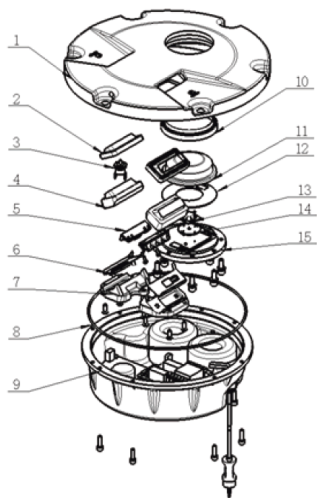

- 1 Upper cover
- 2 Prism gasket sleeve
- 3 Thermal switch
- 4 Prism
- 5 LED lamp assy
- 6 Prism gasket
- 7 Prism pressing bracket
- 8 Light body gasket
- 9 Inner cover assy
- 10 O-prism gasket sleeve
- 11 O-Prism
- 12 O-Prism gasket
- 13 O-LED lens
- 14 O-LED lamp assy
- 15 O-Prism pressing bracket

TDZS-12 | LED In-pavement runway touchdown zone light - Airsafe

Spare Parts

N°	Order No.	Description
2	43117	Prism gasket sleeve
4	31158	Prism
5	932053-RELS-C	LED lamp assy - RUNWAY-C-RELS
6	43316	Prism gasket
7	43241	Prism pressing bracket
8	41135	Light body gasket
10	43115	O-prism gasket sleeve
11	31113	O-prism
13	43322	O-prism gasket
14	979271-C	O-LED lamp assy
15	43217	O-prism pressing bracket

Accessories

N°	Order No.	Description
1	SB-12	12" deep base
2	DB-12	12" shallow base
3	41115	12" base O-ring
4	51121	12" lamp handle
5	ITF-065-066	65W isolation transformer
6	REC7	Moulded type decondary cable receptacle style 7



Weight and Dimensions

	Base	12" shallow base
Packaging size	330x330x150mm ³	350x350x185mm ³
Weight	9,7 kg	14,3 kg